

SABCO by SADEV®

Profili per balaustre in vetro

Profiles for glass balustrades
Perfiles para barandilla en vidrio
Profils pour balustrades en verres
Profile für Ganzglasgeländer



SABCO Sadev Balustrade Concept

Profili per balaustre in vetro

Profiles for glass balustrades

SABCO, Sadev Balustrade Concept, è il sistema di balastra in vetro senza telaio nelle versioni a muro e a pavimento. È particolarmente adatto per applicazioni pubbliche quali aeroporti, stadi, centri commerciali ed edifici. Massima trasparenza e alto grado di sicurezza.

SABCO è stato progettato per soddisfare tutti i requisiti tecnici e di certificazione richiesti del mercato.

SABCO, Sadev Balustrade Concept, is the system for glass balustrade without frame, available for wall and floor mounting. It is particularly suitable for public applications such as airports, stadiums, shopping centers and buildings. Maximum transparency and high level of security.

SABCO has been tested to meet all technical and certification requirements of the market.

Prove Tests

I test sono stati elaborati con vetri di larghezza 500mm

Tests were realized with 500mm width glass panel

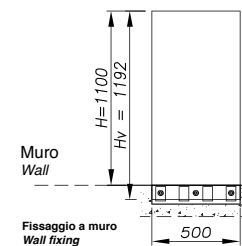
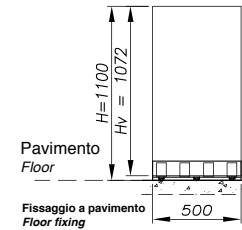

STATIC TESTS:

Inwards horizontal load: Static load was applied on the up-edge glass and was headed inwards.

OUTWARDS HORIZONTAL LOAD:

- Verification by serviceable load (SLS)

The glass balustrade system was tested by serviceable load outwards. The load was applied on the top edge of the glass panel of 1100mm above the floor.

- Verification by ultimate load (ULS)

The glass panel was tested during 15min by ultimate load outwards which is equal to the 3 times of the serviceable load.

DYNAMIC TESTS (by schocking impact):

PERFORMANCE MAINTAINING IMPACT:

- by pendulum test by hard body of 3J energy

ULTIMATE IMPACT:

- by pendulum test by soft body of 900J energy
- by hard body of 10J

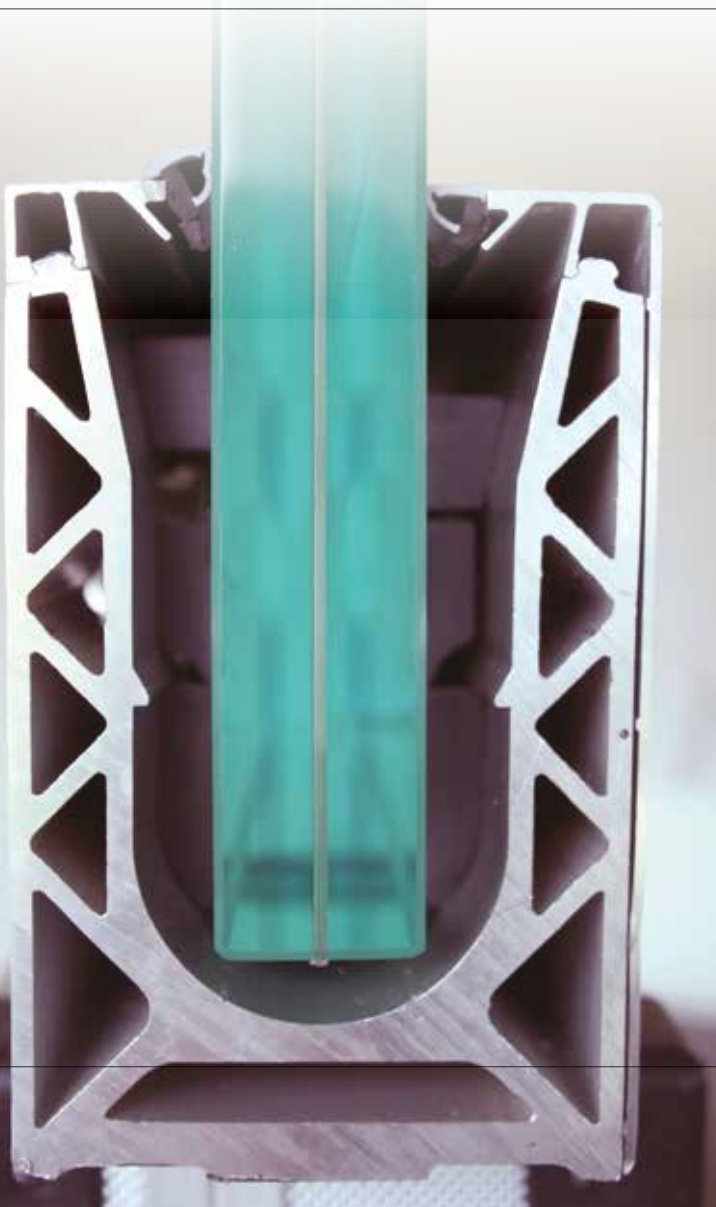

I punti forza di Sabco

Sabco strengths

- 1) Installazione e regolazione in un lampo.
- 2) Angolazione verticale del vetro regolabile di $\pm 2^\circ$.
- 3) In fase di installazione è sufficiente impostare l'angolo e il fissaggio del primo pannello di vetro; gli altri verranno automaticamente corretti in linea.
- 4) Un solo profilo per ogni contesto; il suo adeguamento allo specifico utilizzo e relative norme, dipende dal numero di fori e di pinze utilizzati.
- 5) Muro o pavimento, un solo fissaggio.
- 6) I morsetti interni e l'altezza del profilo rendono la tenuta particolarmente robusta permettendo notevole stabilità e sicurezza anche per piccoli spessori del vetro.

1) Quick mounting and adjustment.

2) $\pm 2^\circ$ adjustment of the vertical glass angle.

3) During installation you only set the angle of the first glass panel and fix it; the other panels will be automatically aligned.

4) Only one profile for any environment; its adaptation to the specific usage and regulations depends on the number of holes and clamps used.

5) One type of fixing only: either wall or floor.

6) The inner clamps and the height of profile make the system particularly robust, giving great stability and security, even for the small glass thickness.

Prestazioni e carichi

Performance & loads

- Qualificato soddisfacente
Qualified satisfy
- Qualificato insoddisfacente
Non-Qualified satisfy

TABELLE DI RIFERIMENTO ALLE NORMATIVE FRANCESI - REFERENCE TABLES OF FRENCH REGULATIONS

Fissaggio a pavimento Floor fixing			
Test dinamico <i>Dynamic test</i>	900 J	900 J	900 J
Test statico <i>Static test</i>	1,8 KN	3 KN	5,1KN
Distanza fori fissaggio <i>Hole fixing distance</i>	400mm	400mm	200mm
Spessore Vetri (S) <i>Glass thickness</i>			
8.8.2 PVB			
8.8.2 EVA		4 pinze/m <i>tapers/m</i>	
8.8.2 Trosifol ES		4 pinze/m <i>tapers/m</i>	
8.8.2 DG41		4 pinze/m <i>tapers/m</i>	
10.10.4 PVB		4 pinze/m <i>tapers/m</i>	
10.10.2 EVA			
10.10.2 Trosifol ES			5 pinze/m <i>tapers/m</i>
10.10.2 DG41			5 pinze/m <i>tapers/m</i>
10.10.2 SentryGlas <small>Non temprato Not tempered</small>	5 pinze/m <i>tapers/m</i>		
12.12.2 SentryGlas <small>Non temprato Not tempered</small>	5 pinze/m <i>tapers/m</i>		
12.12.4 PVB			5 pinze/m <i>tapers/m</i>
12.12.2 EVA			5 pinze/m <i>tapers/m</i>

Fissaggio a muro Wall fixing			
Test dinamico <i>Dynamic test</i>	900 J	900 J	
Test statico <i>Static test</i>	1,8 KN	3 KN	
Distanza fori fissaggio <i>Hole fixing distance</i>	200mm	200mm	
Spessore Vetri (S) <i>Glass thickness</i>			
8.8.2 PVB			
8.8.2 EVA			
8.8.2 Trosifol ES			4 pinze/m <i>tapers/m</i>
8.8.2 DG41			4 pinze/m <i>tapers/m</i>
10.10.4 PVB			4 pinze/m <i>tapers/m</i>
10.10.2 EVA			4 pinze/m <i>tapers/m</i>
10.10.2 Trosifol ES			
10.10.2 DG41			4 pinze/m <i>tapers/m</i>
10.10.2 SentryGlas <small>Non temprato Not tempered</small>			
12.12.2 SentryGlas <small>Non temprato Not tempered</small>	5 pinze/m <i>tapers/m</i>		
12.12.4 PVB			
12.12.2 EVA			

Sistemi di fissaggio *Fixing system*



Fissaggio a pavimento
Floor fixing

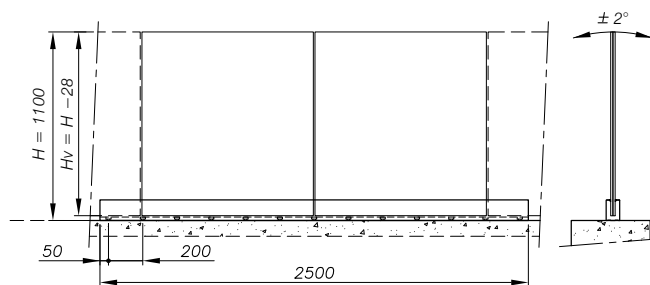
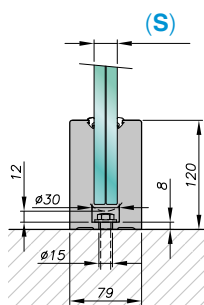

Fissaggio a muro
Wall fixing

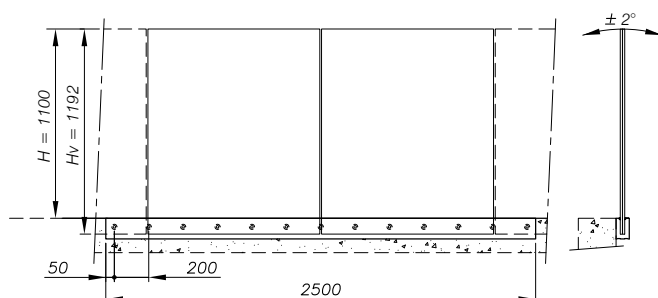
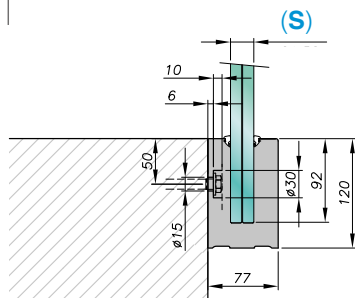

Fissaggio a pavimento Floor fixing	Categoria ★ Class	I	II	III
	SLU Stato Limite Ultimo ULS Ultimate Load		1,5 KN	3 KN
Distanza fori fissaggio Hole fixing distance		400mm	400mm	200mm
Spessore Vetri Glass thickness	(S)			
8.8.2 PVB				
8.8.2 EVA			4 pinze/m tapers/m	
8.8.2 Trosifol ES			4 pinze/m tapers/m	
8.8.2 DG41			4 pinze/m tapers/m	
10.10.4 PVB			4 pinze/m tapers/m	
10.10.2 EVA				
10.10.2 Trosifol ES				5 pinze/m tapers/m
10.10.2 DG41				5 pinze/m tapers/m
10.10.2 SentryGlas <small>Non temprato Not tempered</small>		5 pinze/m tapers/m		
12.12.2 SentryGlas <small>Non temprato Not tempered</small>		5 pinze/m tapers/m		
12.12.4 PVB				5 pinze/m tapers/m
12.12.2 EVA				5 pinze/m tapers/m

Fissaggio a muro Wall fixing	Categoria ★ Class	I	II
	SLU Stato Limite Ultimo ULS Ultimate Load		1,5 KN
Distanza fori fissaggio Hole fixing distance		200mm	200mm
Spessore Vetri Glass thickness	(S)		
8.8.2 PVB			
8.8.2 EVA			
8.8.2 Trosifol ES			4 pinze/m tapers/m
8.8.2 DG41			4 pinze/m tapers/m
10.10.4 PVB			4 pinze/m tapers/m
10.10.2 EVA			4 pinze/m tapers/m
10.10.2 Trosifol ES			
10.10.2 DG41			4 pinze/m tapers/m
10.10.2 SentryGlas <small>Non temprato Not tempered</small>			
12.12.2 SentryGlas <small>Non temprato Not tempered</small>		5 pinze/m tapers/m	
12.12.4 PVB			
12.12.2 EVA			

★ Riferimento tabella 3.1.II NTC 2008 - Norme Tecniche per le Costruzioni Reference table 3.1.II NTC 2008 - Technical Standards for Construction
 Col. I = Cat. A ; B1 ; B2 ; C1 ; H1 ; E1 ; F Col. II = Cat. C2 (scale comuni, balconi, ballatoi ... - common ladders, balconies, walkways ...) ; D1 ; D2 Col. III = Cat. C3

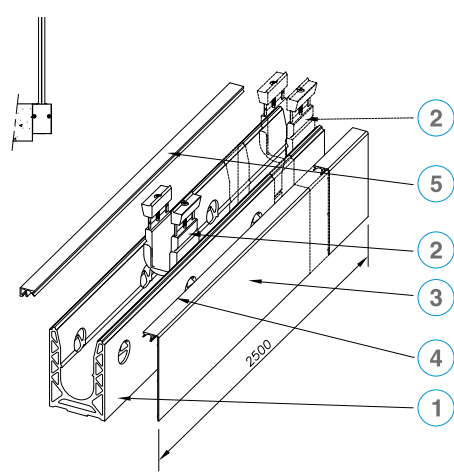
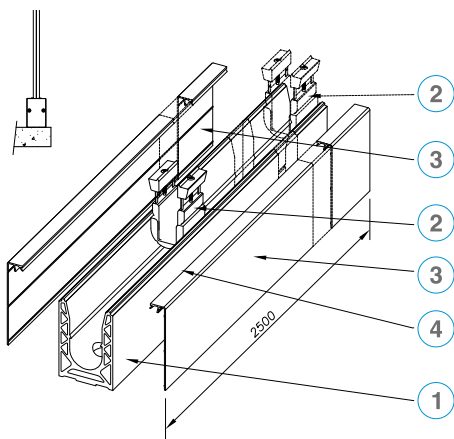

Nel kit In the kit

	Qtà / Qty
① Binario / Rail	1 x 2,5 m
② Pinze / Tapers	10 ÷ 13
③ Carter / Cladding	2 x 2,5 m
④ Guarnizioni / Sealing	2 x 2,5 m

KIT FISSAGGIO A PAVIMENTO FLOOR FIXING KIT

Codice kit Kit item	Lunghezza Length	Spessore Vetri Glass thickness
P21W 08	2,5 m	8.8
P21W 10	2,5 m	10.10
P21W 12	2,5 m	12.12

Binario e carter sono disponibili nella lunghezza di 5m solo su richiesta - Rail and cladding in the length of 5m are available on request only

**Non inclusi nei kit
Not included in the kit**

A Tappo / Cap x 1
 Versione a terra / Floor version P21WP61
 Versione a muro / Wall version P22WP62

B Distanziale adesivo / Template (5mm) x 1 P21WP30

C Spine / Pincers x 1 P21WP50

D Vite autofilettante per calcestruzzo / Self-tapping screw for concrete x 15 P21WP551

E TORX Prolunga per cacciavite / Screwdriver x 1 P21WA11

F Corrimano / Handrail A00W vedi scheda specifica - see specify sheet

Nel kit In the kit

	Qtà / Qty
① Binario / Rail	1 x 2,5 m
② Pinze / Tapers	10 ÷ 13
③ Carter sotto / Low cladding	1 x 2,5 m
④ Guarnizioni / Sealing	2 x 2,5 m
⑤ Carter sopra / High cladding	1 x 2,5 m

KIT FISSAGGIO A MURO WALL FIXING KIT

Codice kit Kit item	Lunghezza Length	Spessore Vetri Glass thickness
P22W 08	2,5 m	8.8
P22W 10	2,5 m	10.10
P22W 12	2,5 m	12.12

Binario e carter sono disponibili nella lunghezza di 5m solo su richiesta - Rail and cladding in the length of 5m are available on request only



Innovazione e sicurezza

La finitura standard dei profili è in alluminio anodizzato; altre finiture quali il simil inox satinato ed il verniciato nella gamma dei colori RAL, sono disponibili su richiesta.

Il profilo SABCO è di soli 120mm di altezza ed è disponibile nella lunghezza standard di 2500mm. I fori per il fissaggio sono da Ø14mm e con distanze da 200 a 400mm, al suo interno si possono inserire vetri stratificati e temprati a partire da spessori di 8.8.2. Supporta vetri con altezza da 1100mm e larghezza da 500 a 2500mm.

Innovation and safety

The standard finishing of profiles is anodized aluminium; other finishings are available on demand, such as imitation satin stainless steel, and painted in the range of RAL colours.

The profile SABCO is only 120 mm high and has a standard length of 2500 mm. The fixing holes are Ø14mm with distances from 200 to 400 mm. Inside you can insert laminated and tempered glasses from 8.8.2 thickness on. It holds glazings with height from 1100 mm and width from 500 to 2500 mm.

Brevettato Patented



ES

SABCO Sadev Balustrade Concept Perfiles para barandilla en vidrio

SABCO, Sadev Balustrade Concept, es el sistema de barandilla en vidrio sin marco – en modelo a pared y al suelo. Es especialmente adecuado para aplicaciones públicas como aeropuertos, estadios, centros comerciales y edificios. Máxima la transparencia y alto el grado de seguridad.

SABCO ha sido testeado para cumplir con todos los requisitos técnicos y los requisitos de certificación del mercado.

Innovación y seguridad

El acabado estándar de los perfiles es aluminio anodizado: otros – acabados como simil acero satinado y pintados en la gama de colores RAL están disponibles por encargo. El SABCO es de 120mm de alto y largo estándar de 2500mm. Los agujeros de montaje son Ø14mm distancias de 200mm a 400 mm; en el interior se puede poner el vidrio laminado y templado de 8+8+2 espesores. Soporta vidrios con altura de 1100mm y anchura de 500mm a 2500mm.

Los puntos fuertes de Sabco

- 1) Instalación y ajuste rápidos.
- 2) Ángulo vertical del vidrio ajustable de $\pm 2^\circ$.
- 3) Durante la instalación es suficiente ajustar el ángulo y la fijación del primer panel de vidrio; los otros paneles, que serán corregidos en línea.
- 4) Un perfil para cada contexto; su adaptación al uso específico y sus reglas, dependerán del número de agujeros y pinzas usata.
- 5) Pared o suelo: sólo un tipo de fijación.
- 6) Las abrazaderas internas y la altura del perfil, hacen el estanco particularmente robusto que permite la estabilidad y la seguridad incluso para pequeños espesores del vidrio.

FR

SABCO Sadev Balustrade Concept Profils pour balustrades en verres

SABCO, Sadev Balustrade Concept, est un système pour balustrades en verre sans cadre, disponible en montage latéral ou au sol. Il est particulièrement adapté pour des applications publiques telles que les aéroports, les stades, les centres ou bâtiments commerciaux. Transparence maximale et degré élevé de sécurité.

SABCO a été testé pour répondre à toutes les exigences techniques et réglementaires du marché.

Innovation et sécurité

La finition standard des profils est l'aluminium anodisé. D'autres finitions, telles que l'aspect inox brossé ou peinture suivant les couleurs RAL, sont disponibles sur demande. Le profil SABCO a une hauteur de 120 mm seulement et une longueur standard de 2500 mm. Les trous de fixation sont en Ø14mm avec des distances de 200 à 400 mm. A l'intérieur, on peut insérer des verres feuilletés et trempés d'épaisseur 8,8,2 ou plus. Il supporte des verres d'une hauteur de 1100mm et largeur de 500 à 2500mm.

Atouts de Sabco

- 1) Montage et réglage très rapide.
- 2) Réglage de $\pm 2^\circ$ de l'angle vertical du verre.
- 3) Lors de l'installation, il suffit de régler l'angle du premier verre et le fixer à l'aide d'un niveau; puis se caler sur celui-ci pour fixer les autres verres.
- 4) Un seul profil pour chaque contexte : son adaptation à l'utilisation spécifique dépendra du nombre de trous et pinces utilisés.
- 5) Un seul type de fixation: au mur ou au sol.
- 6) Les cales internes et la hauteur du profil rendent le système particulièrement robuste en offrant une grande stabilité et sécurité mêmes avec petits épaisseurs de verre.

DE

SABCO Sadev Balustrade – das Konzept Profile für Ganzglasgeländer

Das Balustraden Konzept SABCO von SADEV, ist ein rahmenloses System für Ganzglasgeländer und kann sowohl vorgesetzt wie auch aufgesetzt montiert werden. Das SABCO System ist besonders für den öffentlichen Bereich, wie z.B. Flughäfen, Stadien, Shopping-Center und Bürogebäuden geeignet. Höchster Maß an Transparenz und hohes Niveau an Sicherheit.

SABCO wurde auf alle technischen Anforderungen des Marktes getestet.

Innovation und Sicherheit

Die Standard Oberfläche des Profils ist Aluminium EV 1 eloxiert; andere Oberflächen sind auf Anfrage möglich, wie z.B. Edelstahlähnlich, oder RAL-beschichtet. Das SABCO Profil ist nur 120 mm hoch und hat eine Standardlänge von 2500 mm. Die Befestigungslöcher haben einen Durchmesser von Ø14mm mit einem Abstand von 200 bis 400 mm. Verbund-sicherheitsglas und vorgespanntes Glas mit einer Glasdicke von 8.8.2 kann verwendet werden. Das Profil kann Glasscheiben mit einer Höhe von 1100 mm und einer Breite von 500 bis 2500 mm halten.

Vorteile von SABCO

- 1) Schnelle Montage und Justierung.
- 2) $\pm 2^\circ$ Justierungsspielraum des vertikalen Glaswinkels.
- 3) Während des Einbaus muss nur der Winkel der ersten Glasscheibe bestimmt und festgestellt werden; die folgenden Scheiben werden automatisch ausgerichtet.
- 4) Nur ein Profil für jedwede Umgebung; über die Anzahl der Befestigungslöcher und Klammern, kann das Profil für den spezifischen Einsatz angepasst werden.
- 5) Es gibt nur eine Befestigungsebene: entweder seitlich oder am Boden; nie an beiden.
- 6) Die Innenklammern und die Höhe des Profils machen das System extreme robust, verleihen ihm ein hohes Maß an Stabilität und Sicherheit, selbst bei geringeren Glasdicken.

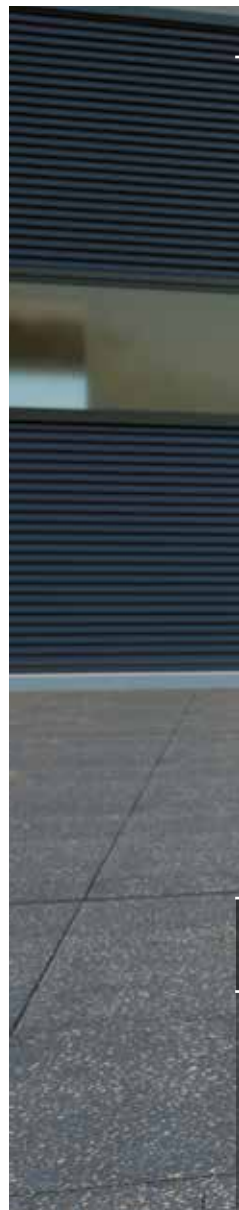

Minusco

Tel. (+39)0302532008 - (+39)0302530289

Fax. (+39)0302534707

info@minusco.com - www.minusco.com



Colcom Group S.r.l. a socio unico

www.colcomgroup.it

Via degli Artigiani, n°56 int.1 - 25075 Nave (Brescia) - Italy